

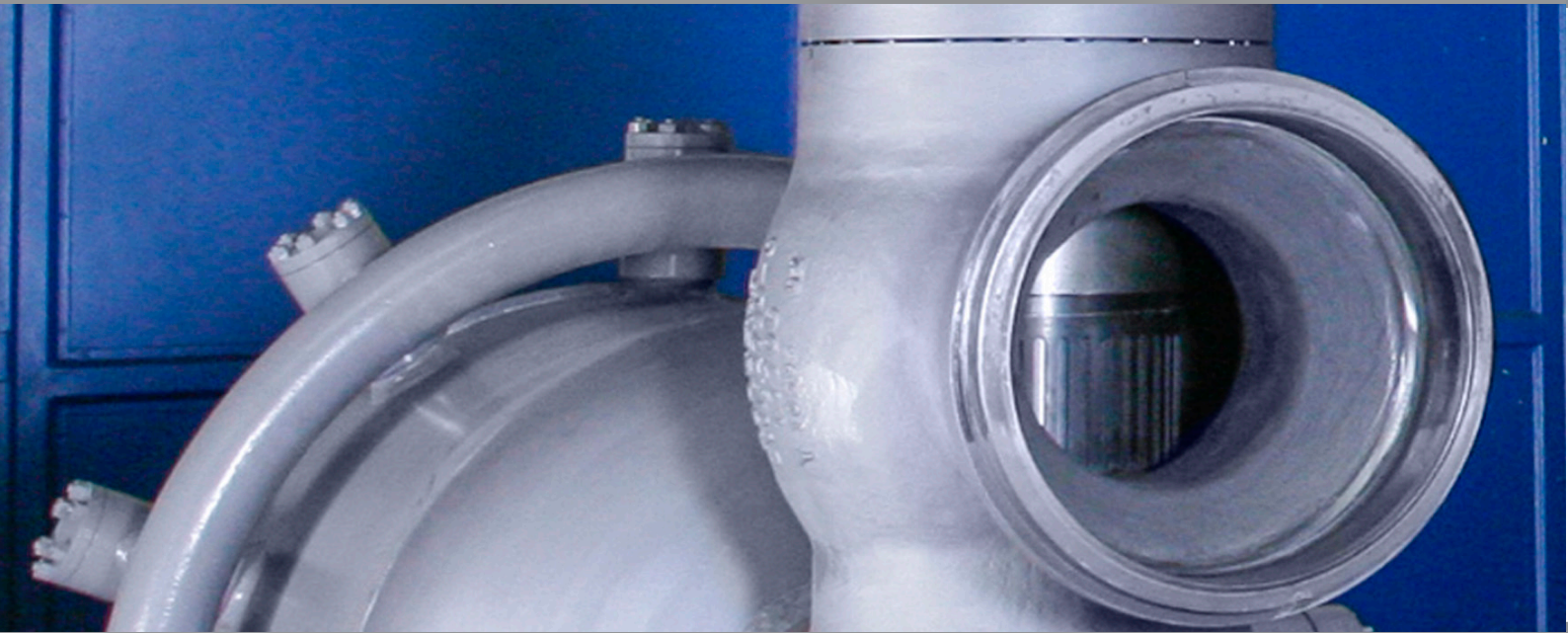

BOMAF[®]
Special Valve Solutions

www.bomafa.de



Steam Conditioning Valves and Turbine Bypass Systems

- Low noise
- High controllability
- Durable
- Safe

BOMAF Valves



Power
(1000 MW)



Chemistry



Industry

BOMAF develops and produces high-quality valves for steam, gas and water. The valves are used in nearly all kinds of power plants, chemical and petrochemical plants and a range of various other industrial applications.

Increased plant efficiency by customized steam conditioning valves



fig. 1

Steam conditioning valves are used in power plants, chemical plants and manufacturing industries to regulate certain steam pressures and steam temperatures.

The combination of many parameters (inlet and outlet pressure, inlet and outlet temperature, connection diameter, flow pattern, capacity and safety function, etc.) often requires an individual design.

BOMAF is specialized to develop customized valves on the basis of given system parameters.

Tailor-made valves are highly efficient because processes can be controlled precisely. These high control accuracy and the processwise optimized desuperheating extend the life of special valves compared to standard valves considerably.

Quality pays in the long run: BOMAF Steam conditioning valves make a valuable contribution to increase plant efficiency for over 90 years.

Technical Data

Diameter nominal	Inlet	Outlet
	DN 25-600 / 1"-24"	DN 50-2500 / 2"-100"
Pressure nominal	PN 16 - PN 630	PN 16 - 630
	Class 150 - Class 4500	Class 150 - Class 4500
Operation temperature	Up to ~650 °C	
Design	Globe-, angle- or Z-designs. Special designs upon request. Both flow-over and flow-under stem applicable. Piping connections with weld ends or flanges according to DIN, ASME or I.B.R.	
Control characteristics	- Equal percentage / linear / process-specific - Ratio: 1:10 - 1:25 - 1:50 - 1:100	
Sealing	- Metal sealing with leakage class V - Packings of pure graphite - Stellite or nitrided surfaces of the seats and spindle- hole bush systems	
Actuators	- Pneumatic or hydraulic actuators (Product partnership with asfa Antriebssysteme GmbH of BOMAF Group) - Electric actuators - Lever actuators	
Safety functions	- Quick opening / quick closing in less than one second - Quick opening / quick closing supported by direction of flow - Spring support for opening or closing - Spare strokes for hydraulic and pneumatic actuators	
Noise	By standard < 85 dB(a) with insulation. Lower noise levels can be applied upon request.	
Quality standards	BOMAF valves are manufactured in accordance with the requirements of PED 97/23/EC and DIN ISO 9001. ASME or I.B.R. upon request.	

Actuators

- Regulating times of < 1. sec.
- Hydraulic
- Pneumatic
- Electric
- Safety function as option

Cover sealing

- Low pressure: Bolted bonnet
- High pressure: Self sealing

Body

- Flow-optimized
- Temperature-optimized
- Forged materials
- Casting

Desuperheating

- Precisely matched to load case
- Motive steam
- Downstream pressurized atomization
- Integrated injection

Pressure reduction

Single- or multi-stage spindle-hole bush systems of forged materials

Design Features

Low noise emissions by subcritical multi-stage pressure reduction.

Customized multi-stage pressure control over the entire load range.

Both flow-under and flow-over stem applicable.

Durable due to optimized adjustment to the overall process.

Service-friendly due to modular design.

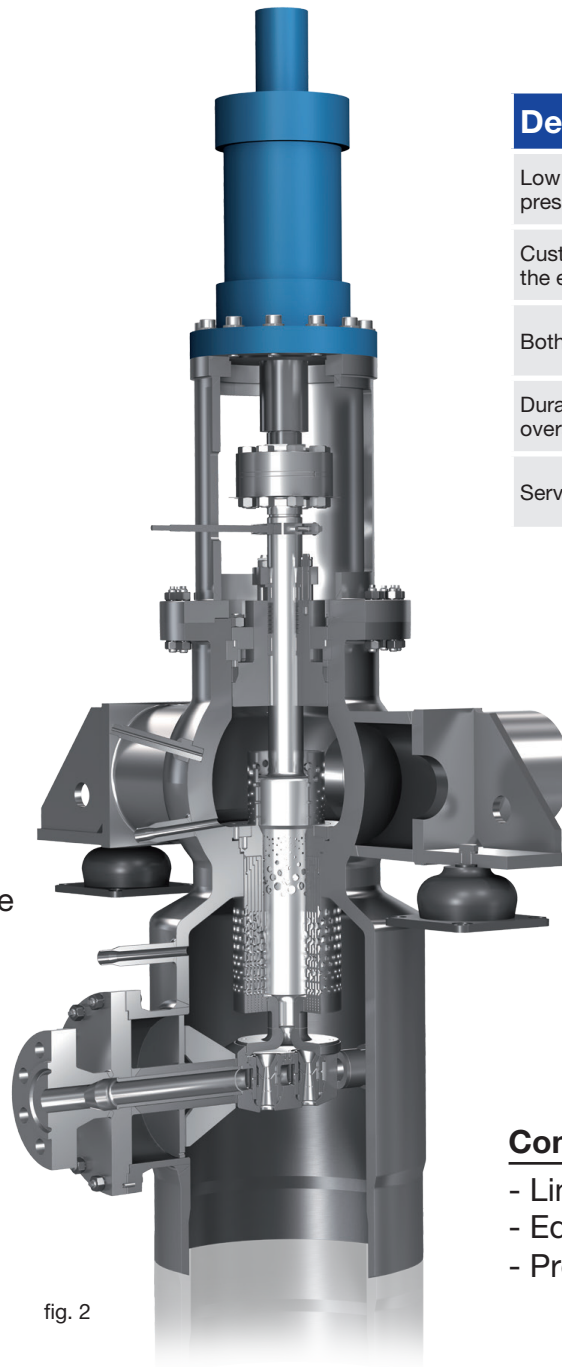
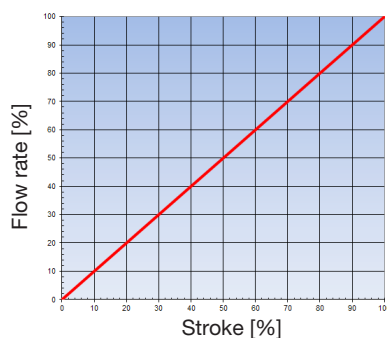

fig. 2

Control characteristics

- Linear (1)
- Equal percentage (2)
- Process-specific (3)



(1)

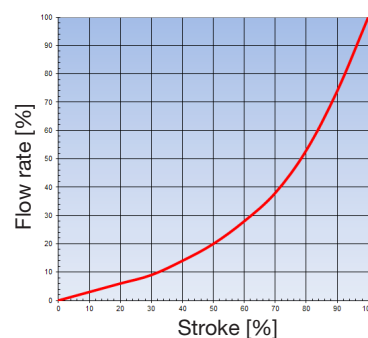

(2)

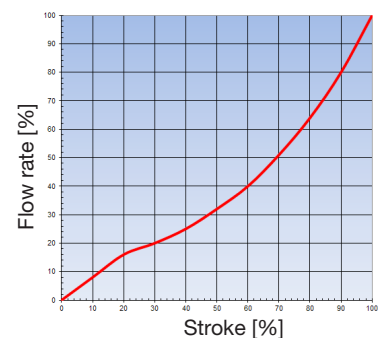

(3)

High controllability

Subcritical pressure reduction

BOMAFA steam conditioning valves conduct a stagewise subcritical pressure reduction by spindle-hole bush systems. That means, that a critical pressure ratio between two consecutive stages is not exceeded.

The perforated area between the individual pressure stages represent the narrowest flow cross section. It increases during a multi-stage expansion of medium from stage to stage.

The pressure reduction is precisely adjusted to the required pressure reduction for all load cases.

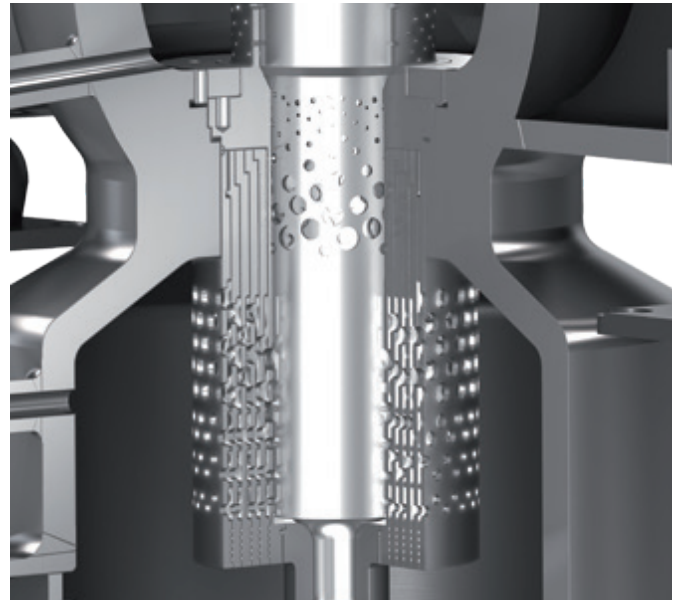

fig. 3: Full controllability and multistage pressure reduction over all stroke ranges

Low noise

Avoidance of unacceptable noise emissions

1: Avoidance of compression shocks: BOMAFA optimizes flow patterns through flow simulations.

2: Avoidance of free jet noises: Pressure reduction takes place stepwise subcritically in all BOMAFA valves. Free-jets with extreme velocities are prevented from emerging.

3: Avoidance of turbulent flows and vortex sheddings. In BOMAFA valves there are no contour steps, which are a major cause of vortex sheddings.

4: Calculation of noise level according to VDMA 24422 and DIN EN 60534-8-3:2011-10.

Safe and efficient desuperheating

Desuperheating at Steam Conditioning Valve

Motive steam assisted desuperheating

- Desuperheating to 5 °C above saturated steam temperature
- Optimized for loads < 5% of max. capacity
- Short evaporation distances
- High controllability of temperature

A motive steam assisted desuperheating will be selected for critical applications - cooling close to saturated vapor, small volumes of flow or continuous operation. The motive steam is taken after the first pressure reduction stage and passed through a nozzle. There it is accelerated by the design of the nozzle together with the injected water and then mixed. This procedure requires only very short evaporation distances.

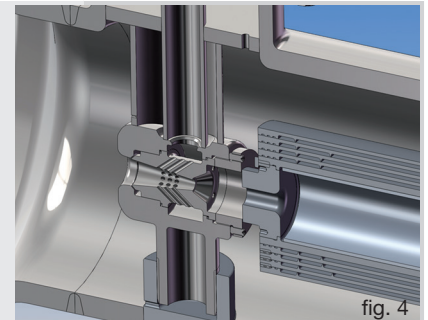

Downstream atomization

- Optimized for temperatures significantly above saturation temperature
- High robustness
- Modular installation

In case of steam temperatures above saturation temperature, the water is injected separately after conduction of pressure reduction. A special nozzle located centrally in the steam flow ensures a rapid and safe evaporation.

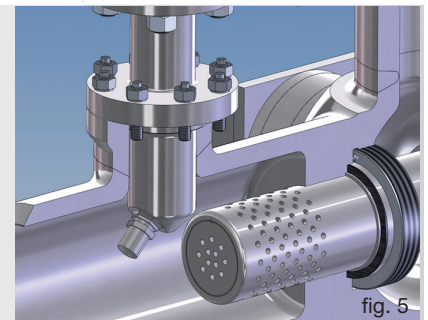

Downstream atomization by radial desuperheater

- Optimized for the injection of large water loads
- High robustness
- Easy exchange of single nozzles

Radial desuperheaters are based on the principle of pressurized atomization. By their design with up to 21 nozzles, they are particularly suitable for the injection of large amounts of water. The individual nozzles are connected with a ring line. The injection of water is controlled via a separate valve and the spring load of the individual nozzles. Steam conditioning valves with radial desuperheaters are used in modern large-scale power plants for cooling large quantities of steam, especially in pipes leading to condensers.

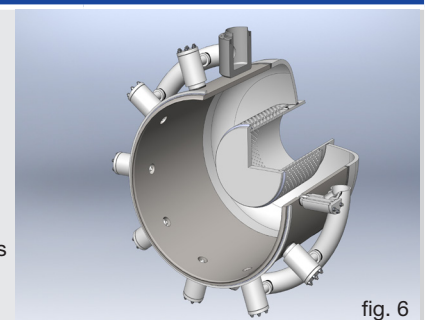

Integrated injection

- Very fast evaporation
- Efficient protection of the downstream pipeline from water droplets
- Shortest evaporation distances

The water is injected after the first pressure reduction stage (spindle) into the seat bush. The very high steam pressure and the following reduction stages leads to an optimized further mixing. The integrated injection is ideal for valves with long stand-by mode and short evaporation distances.

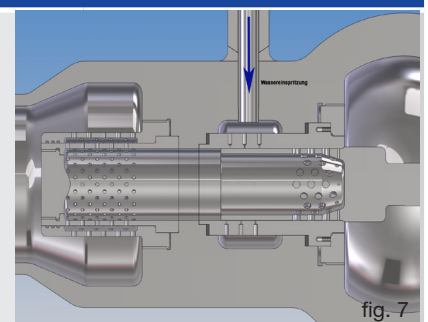

Pressure reduction in LP-systems

Dump Tubes

Dump tubes are used in applications where the pressure of gas or vapor-like media is greatly reduced. They are used mostly after LP-Steam conditioning valves at the transition to a condenser.

The great advantage of a dump tube is that a multi-stage pressure reduction and the resulting expansion of the pipe diameter (partly over DN 2500) can be implemented inexpensively.

They also significantly contribute to the control of noise emissions.



fig. 8: BOMAFA develops and manufactures dump tubes for nearly all kinds of steam systems.

Reduction of actuator forces

Pressure-balanced spindles

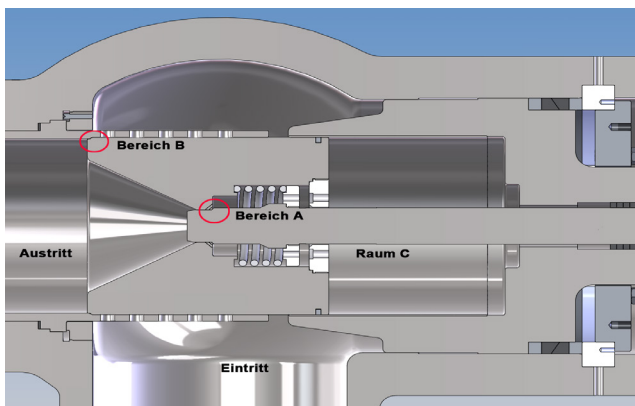

fig. 9: Function:

First, a small gap in the seating area A is opened so that the pressure equalization in the relief space C can take place. After that, the large seat in region B will open with lower actuator force.

At high pressures and large seat diameters, large forces can be necessary to open a valve.

To reduce opening forces and to allow the use of smaller actuators, BOMAFA offers pressure-balanced versions of the control spindles.

Turbine Bypass Systems

Complete HP-IP-LP Systems

- Bypass valves
- Shut-off valves
- Water injection control valves
- Desuperheaters
- Dump tubes
- Actuators

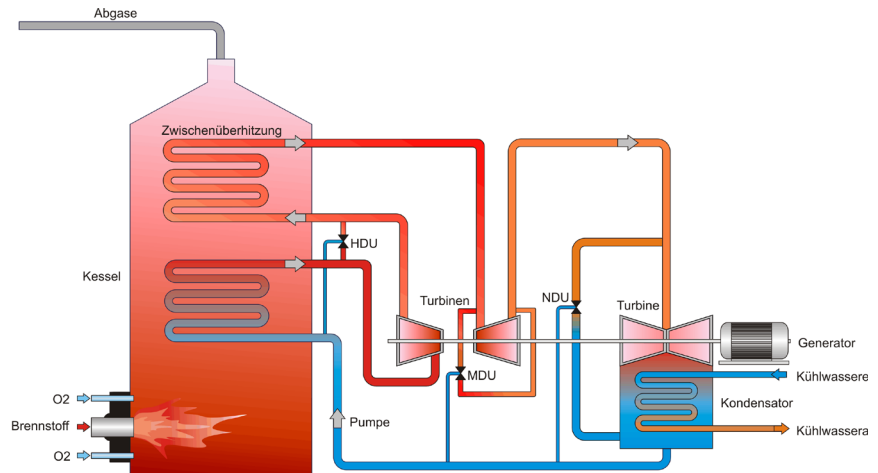

fig. 10

Safe and rapid steam takeover

Turbine bypass valves are steam conditioning valves that meet specific requirements: They are used for bypassing, to protect and to start up steam turbines.

Steam pressure and temperature can be adjusted precisely according to the parameters of the following system during bypass operation.

In addition, BOMAFA optimally fits all high-, medium-, and low pressure bypass systems to the particular local circumstances.

Protection of turbines

Rapid steam takeover
(Opening < 1 sec.).

High reliability (min. SIL 2).

Opening supported by direction of flow.

Safety function by spring or spare strokes (pneumatic / hydraulic actuators).

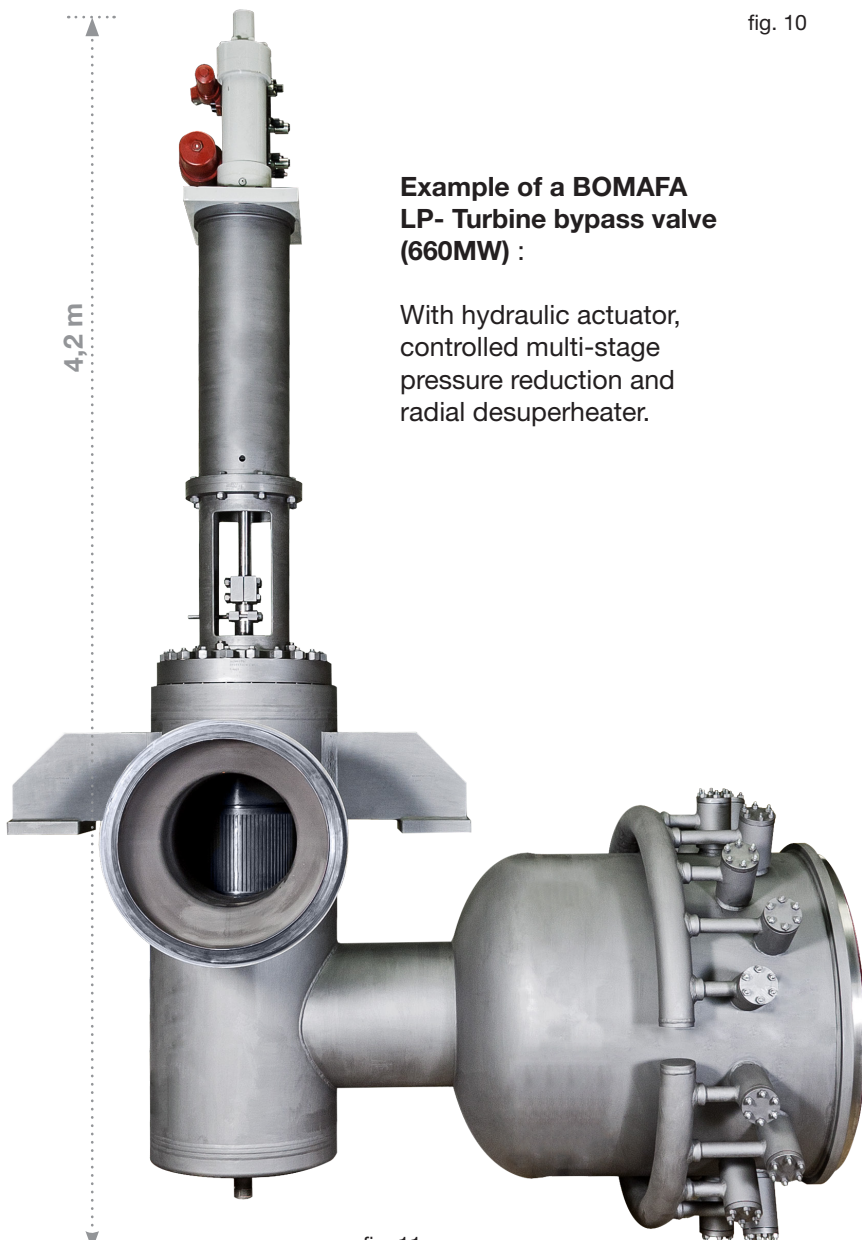

fig. 11

Example of a BOMAFA LP- Turbine bypass valve (660MW) :

With hydraulic actuator, controlled multi-stage pressure reduction and radial desuperheater.

Actuator systems

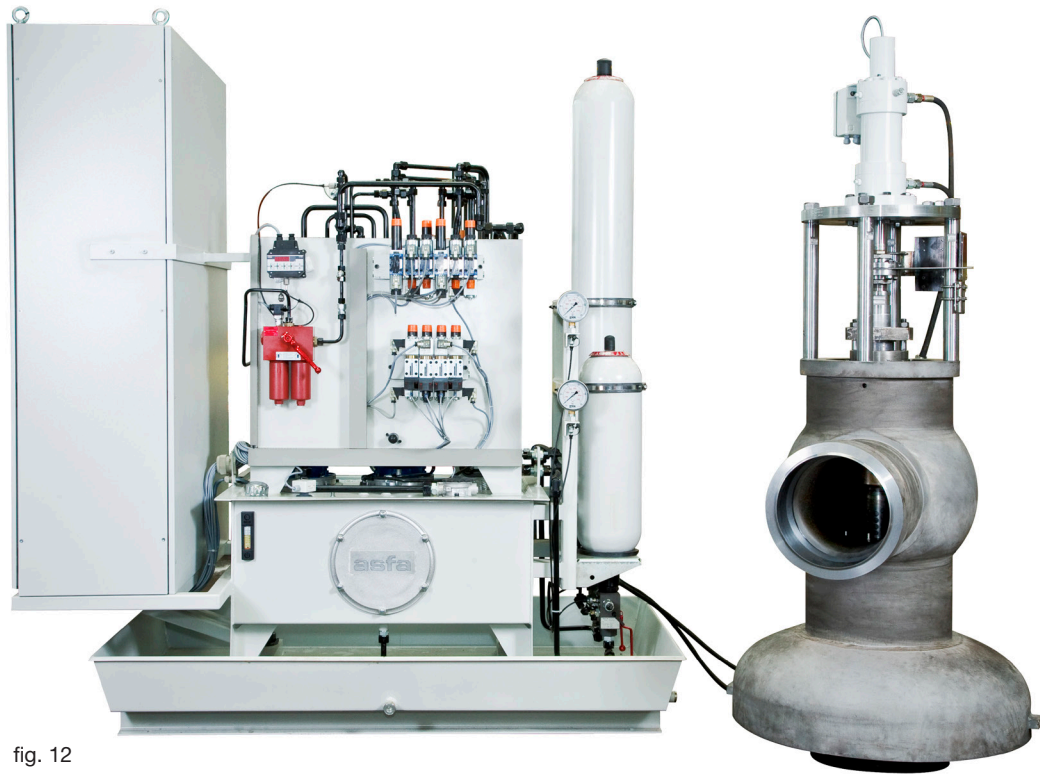

fig. 12

Valves and actuator systems from a single source

<p>Hydraulic- and pneumatic cylinders</p>	<p>A characteristic of all cylinders is their long durability. This is i.a. ensured by the use of quality materials in guiding and sealing elements.</p> <p>Types of cylinders:</p> <ul style="list-style-type: none"> - Differential or synchronous cylinders. - Single or double acting, with or without spring. - Optionally with position transmitter and limit switches.
<p>Hydraulic control units</p>	<p>Design, project work and delivery of Hydraulic Control Units carried out according to specification. Available for all fields of application including installation, commissioning and maintenance.</p> <p>Description:</p> <ul style="list-style-type: none"> - Hydraulic actuation of up to 18 control valves per unit - Quick opening with spring support in 0,1 sec. - Servo control with operating time of 0.3 sec. for the entire stroke, and for intermittent operation - Execution of the complete drive unit in explosion protection
<p>Electric control cabinets</p>	<p>Design, fabrication, installation and commissioning of Electric Control Systems and Actuators. Programming of SPC-Control Systems (e.g. SIMATIC).</p> <ul style="list-style-type: none"> - Pressure and temperature control with microprocessor control electronics in 6 HE chassis - Version with 9" monitor and 16. keypad for programming the individual control parameters - The setpoint and actual values are displayed on-line on the monitor, as well as all manual and automatic functions
<p>Testing</p>	<p>All BOMAFA valves and actuator systems are tested on our self-developed test bench for accuracy and functionality prior to delivery.</p>

BOMAFA Armaturen GmbH

Hohensteinstr. 52
44866 Bochum / Germany

☎ +49 (0) 2327 992 - 0
☎ +49 (0) 2327 314 - 43

✉ info@bomafa.de
🌐 www.bomafa.de